

WORKSTEAD

INSTALLATION INSTRUCTIONS | CHAMBER SCONCE



GENERAL NOTES

This luminaire is UL, cUL, and CE listed for installation in dry or damp locations.

When installing luminaire, conform to all applicable local electrical codes, ordinances, and the National Electrical Code (NEC).

For your safety and proper operation of luminaire, read and understand all instructions completely before commencing installation of this luminaire.

Carefully unpack the luminaire and inspect for damage.

Use the enclosed gloves when handling the luminaire.

This product is rated for one (1) 60W max E12 G16 bulb (or E14 G50 bulb, depending on your location).

Save these instructions for future reference.

CAUTION

This product should be installed only by a licensed electrician.

WARNING

The electricity must be turned off at the main fuse box before installing this luminaire. Turning power off using the light switch may not be sufficient to prevent electrical shock.

Use UL listed wire nuts for all wiring connections in this luminaire. Wrap wire nut connections with UL listed electrical tape.

INCLUDED COMPONENTS FOR INSTALLATION



(1) luminaire body

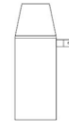

(1) shroud assembly



(1) socket sleeve



(1) shroud set screw



(1) mounting plate



(1) E12/E14 bulb



(4) 1-1/2" #8 x 32 machine screws



(2) acorn nuts



(3) wire nuts

ASSEMBLY AND MOUNTING INSTRUCTIONS

STEP 1 | CUT POWER

Shut off the main electrical supply to the junction box from the fuse box/circuit breaker. Turning power off at the switch is not sufficient.

STEP 2 | ATTACH MOUNTING PLATE

Locate the junction box in the wall. Install (2) 1-1/2" #8 machine screws provided into the outer holes of the mounting plate, from the back side, to act as mounting studs. Attach the mounting plate provided to the junction box using (2) 1-1/2" #8 x 32 machine screws provided. (Fig. 1)

STEP 3 | CONNECT WIRES

Using the wire nuts provided, make electrical connections by following the electrical configuration table. (Fig. 2) Ensure that all electrical connections are wrapped with UL listed electrical tape.

STEP 4 | SECURE BACKPLATE

Carefully tuck the wiring into the junction box. Carefully align the two holes in the backplate with the mounting stud screws and slip the backplate over those screws. Attach and tighten the two acorn nuts provided to those screws to secure the luminaire to the wall. NOTE: Tighten acorn nuts by hand or using soft-touch pliers. (Fig. 3)

STEP 5 | INSTALL BULB

Install the socket sleeve provided by sliding it over the socket. Install the bulb provided. Return power to the luminaire. Turn the dimmer dial to confirm proper function. If further work is needed, be sure to turn off power to luminaire before proceeding.

STEP 6 | INSTALL SHROUD ASSEMBLY

Unscrew the finial from the top of the luminaire and slide the shroud assembly down the stem until it rests on the luminaire base. (See Fig. 4 on page 4)

Fig. 1

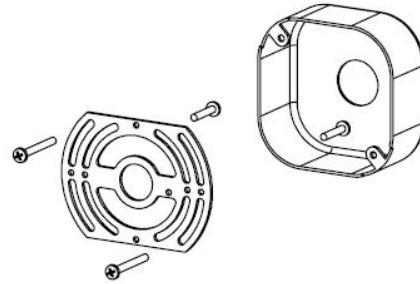
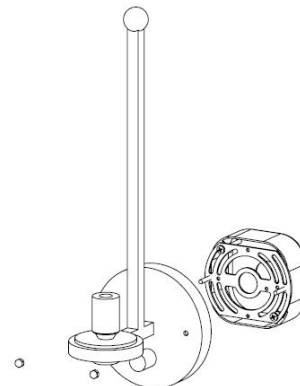

Fig. 2

FROM SUPPLY	TO LUMINAIRE
Connect black or red (hot) house supply circuit wire to:	Luminaire black wire (hot)
Connect white (neutral) house supply circuit wire to:	Luminaire white wire (neutral)
Connect green insulated or bare copper (ground) house supply circuit wire to:	Luminaire bare copper wire (ground)

Fig. 3



ASSEMBLY AND MOUNTING INSTRUCTIONS

STEP 7 | ADJUST SHROUD

Screw the finial back onto the top of the luminaire. Lightly thread the shroud set screw provided into the side hole of the shroud holder, adjust height of shroud as desired, and tighten shroud set screw gently to secure. (Fig. 4) PLEASE NOTE: DUE TO THE NATURE OF THIS OPERATION, MARKS MAY APPEAR ON THE STEM. DETERMINE DESIRED SHROUD LOCATION BEFORE GENTLY TIGHTENING SET SCREW.

Fig. 4

